

Features

1. Extremely low height for use in confined space
2. Safety lock nut for mechanical load holding
3. Leaning load saddle
4. High flow 3/8-18NPT quick couplers
5. High strength alloy steel for durability and safety
6. Overflow port function as a stroke limiter

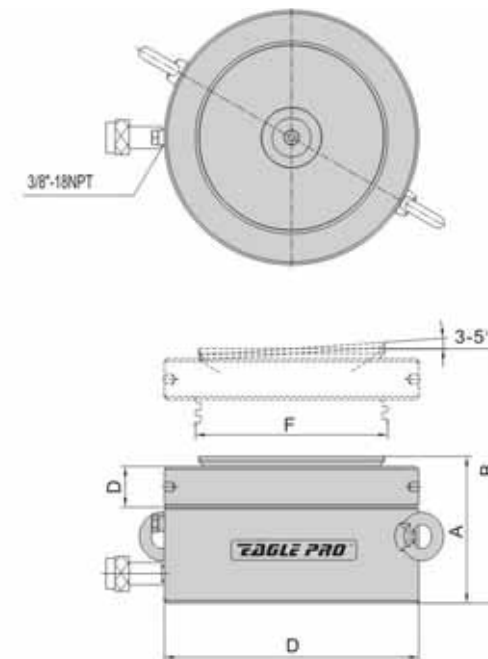

Capacity @ 700 bar tonne	60	100	160	200	260	400	520
Stroke mm	50			45			
Product Code	PPLC602	PPLC1002	PPLC1602	PPLC2002	PPLC2502	PPLC4002	PPLC5002
Oil Capacity cm ³	433	715	1021	1275	1633	2481	3286
Effective Area cm ²	86.6	143	226.9	283.9	362.9	551.3	730.3
Collapsed Height A mm	125	137	148	155	159	178	192
Extended Height B mm	175	187	193	200	204	223	237
Lock Nut Height C mm	28	31	40	43	44	55	62
Outside Diametre D mm	140	175	220	245	275	350	400
Saddle Diametre E mm	96	126	160	180	200	250	290
Piston Rod Diametre F mm	Tr104x4	Tr134.5x6	Tr170x6	Tr190x6	Tr215x6	Tr265x6	Tr305x6
Weight kg	15	26	44	57	74	134	189



The information contained in this brochure is to be used as a guide only, specifications are subject to change without notice.